



Utförandeförslag - Gästhus  
Fastigheten 1:24

PROJEKT: Exempel 1:24  
DATUM: 2021-04-06  
BYA: 30 kvm  
BOA: 25 kvm varav 9 kvm förråd  
+ loftyta 11 kvm  
ARKITEKT: Fredrik Branting  
REV-NR: 00

**Branting**  
Arkitekt & Byggekonsult

# Exteriör

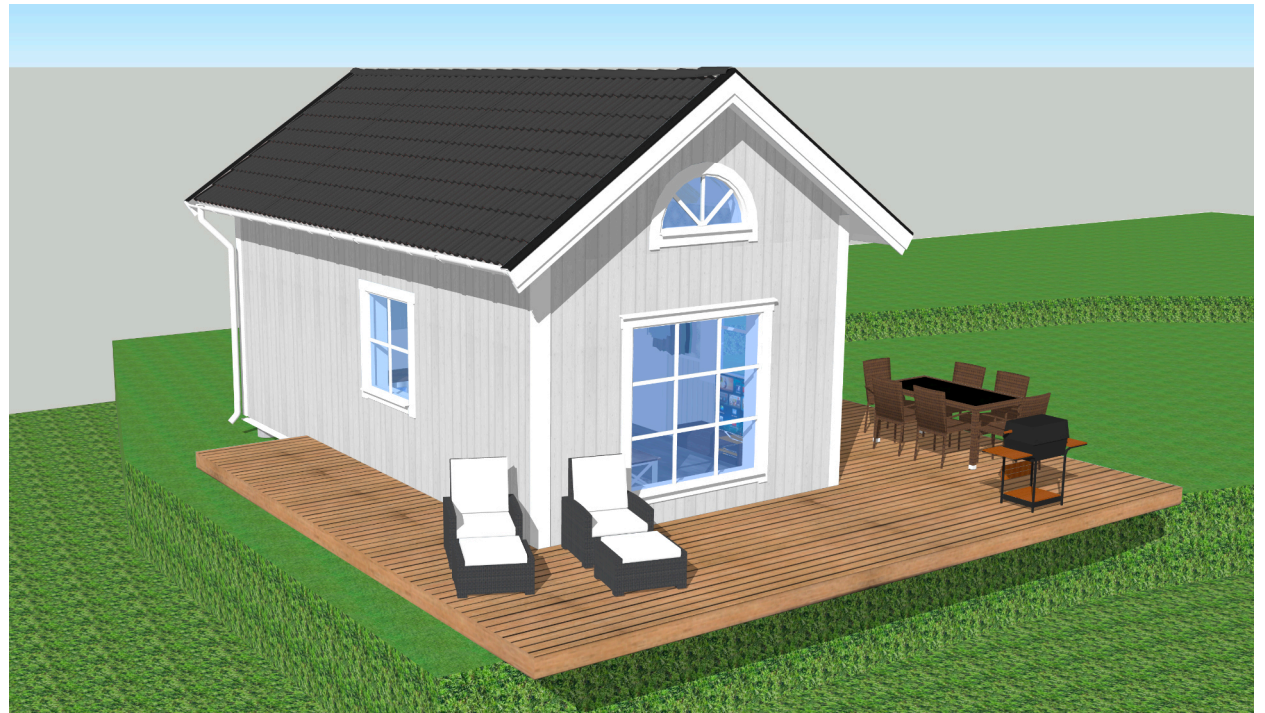
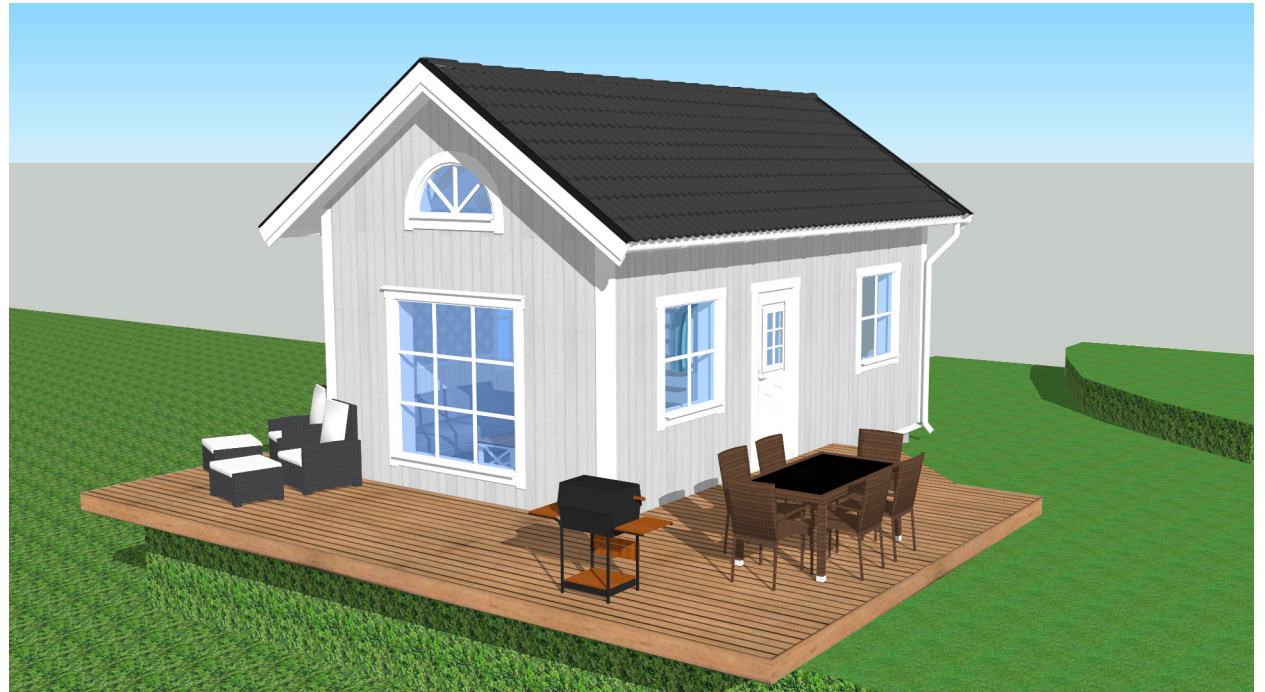

# Exteriör

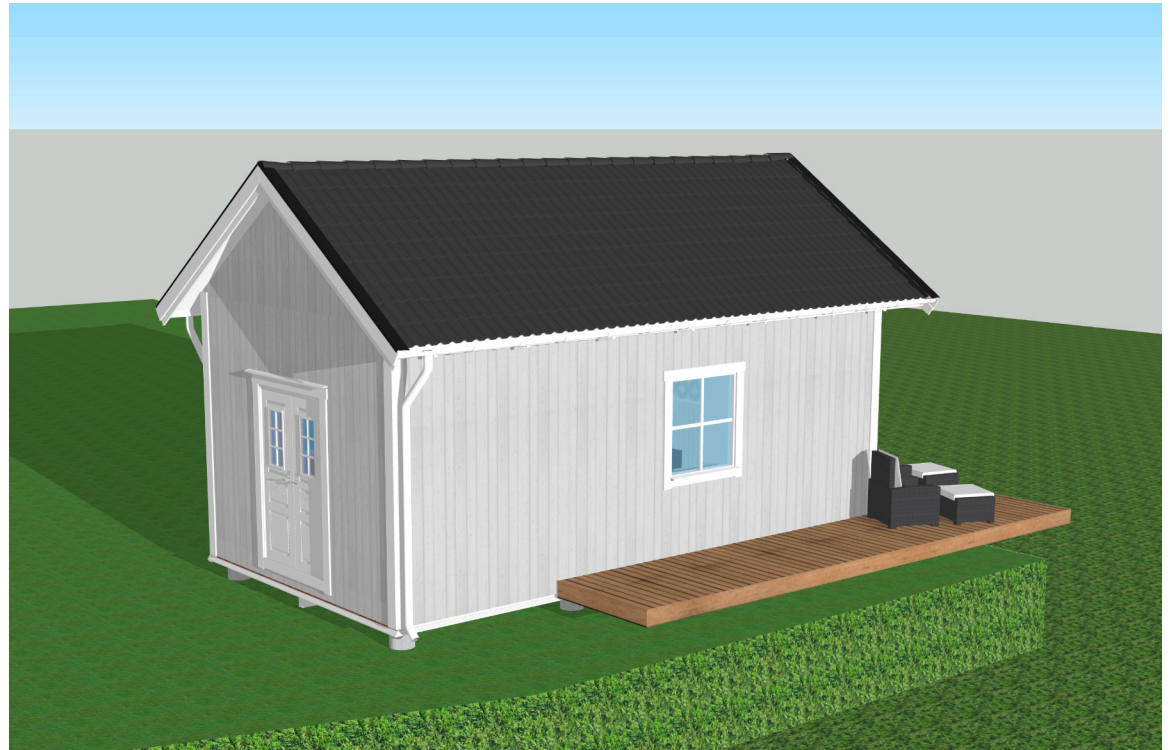
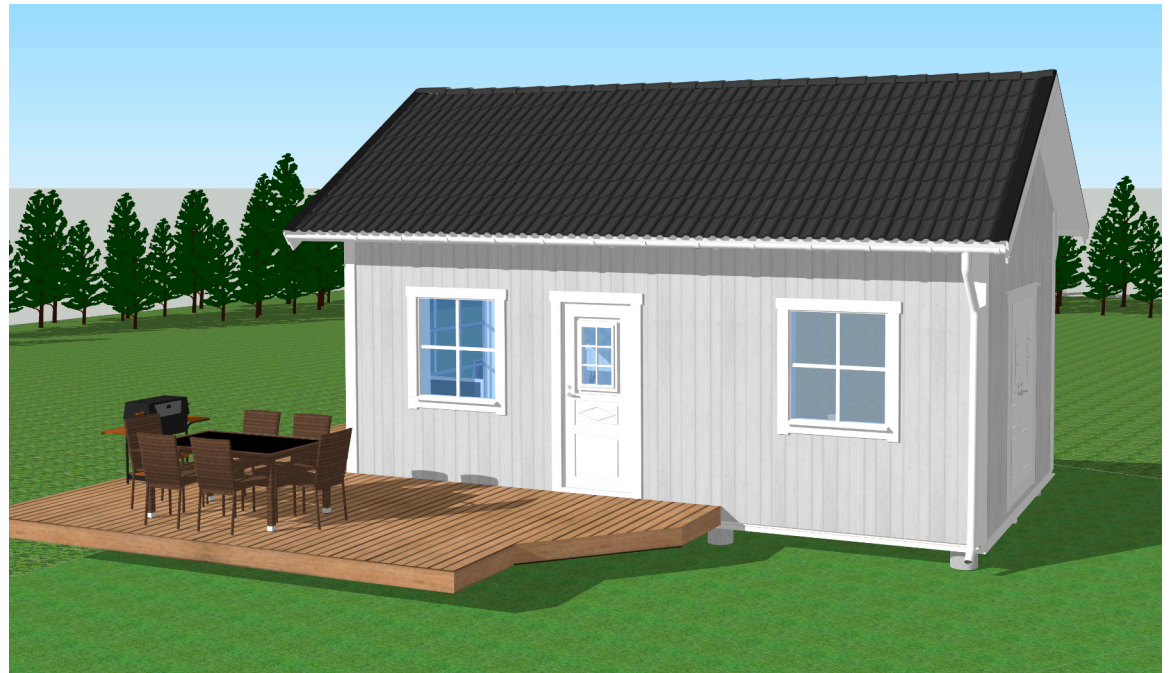

# Interiör - planlösning



# Interiör - Detalj-idéer



# Toaletten

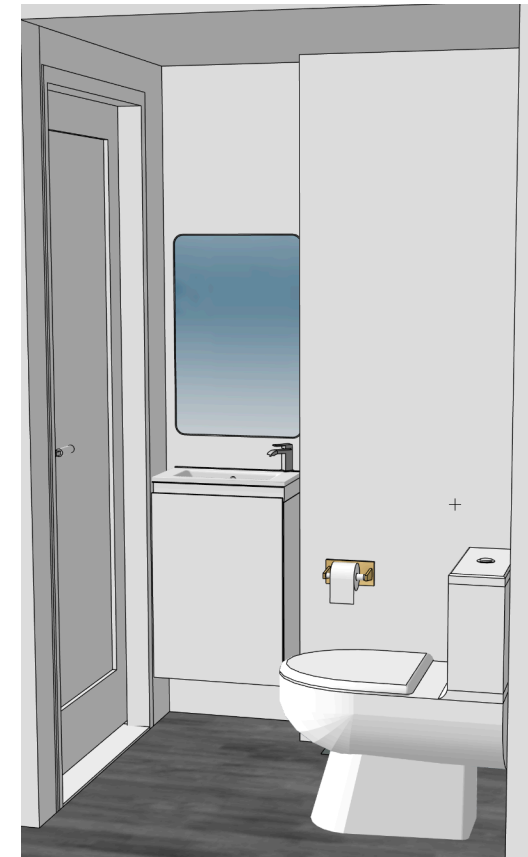

# Loftet

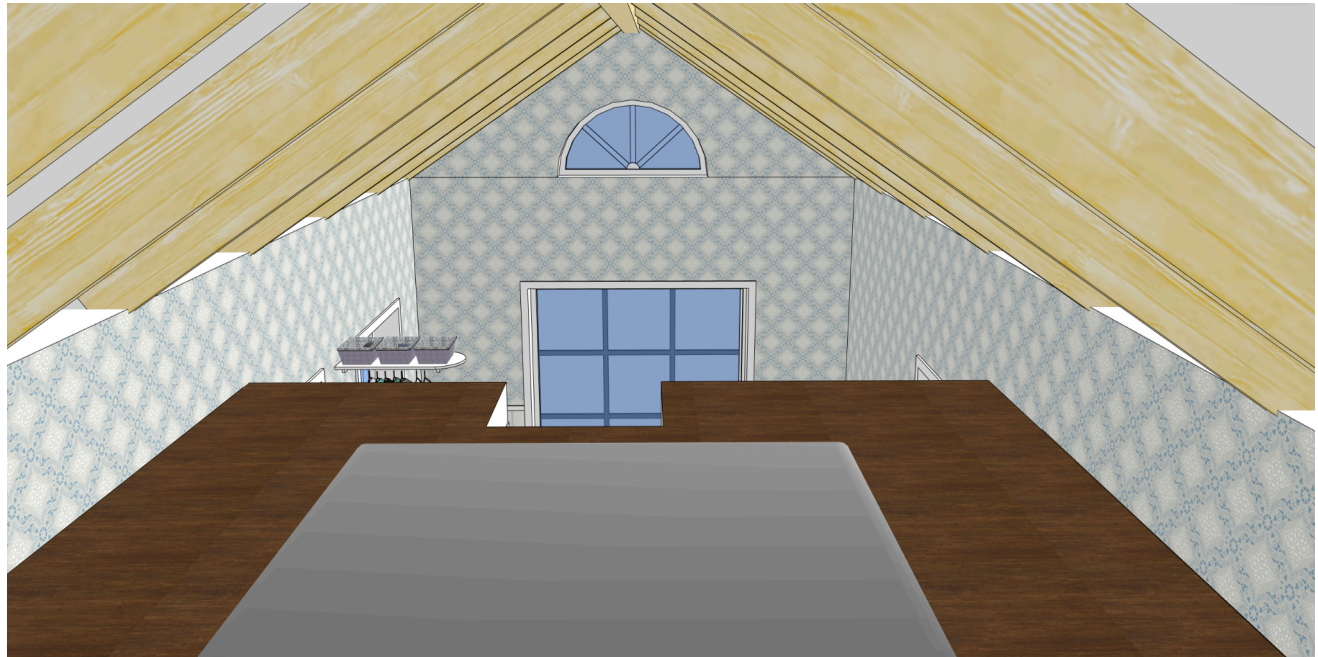

# Förrådet

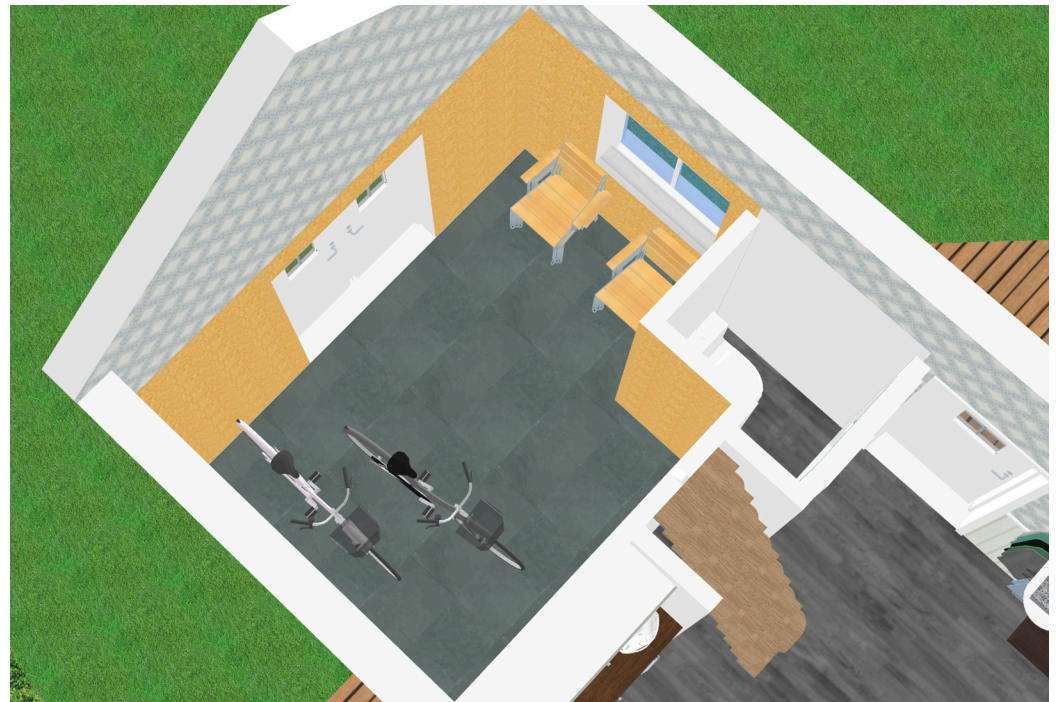
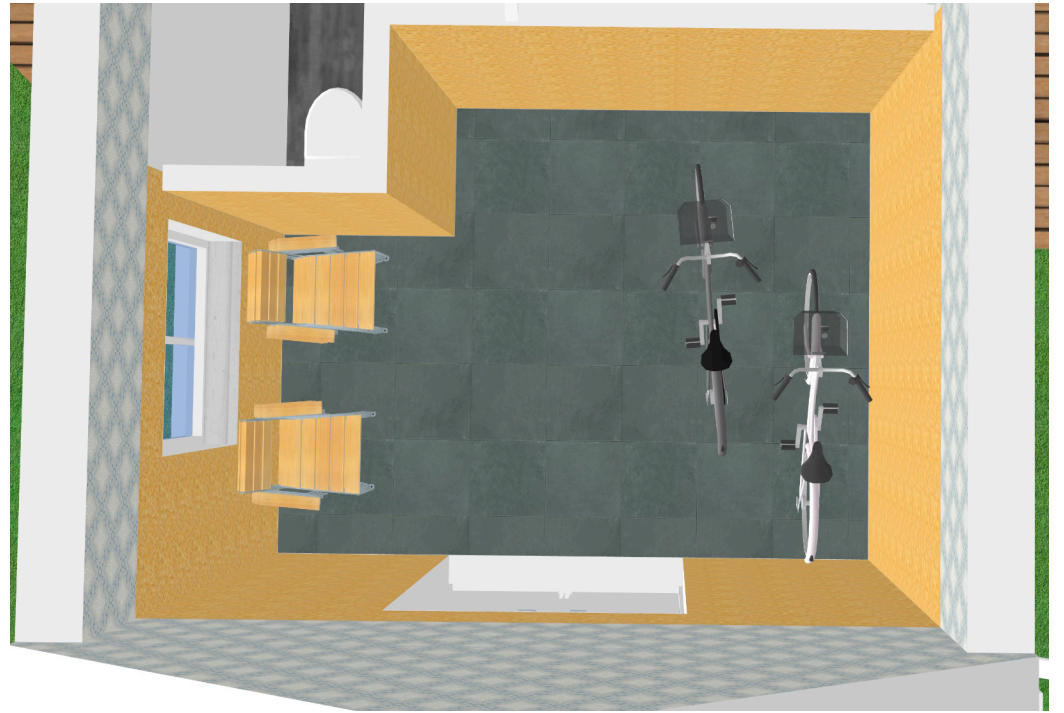



# Solstudie

Framsida 18/7 kl 14:00

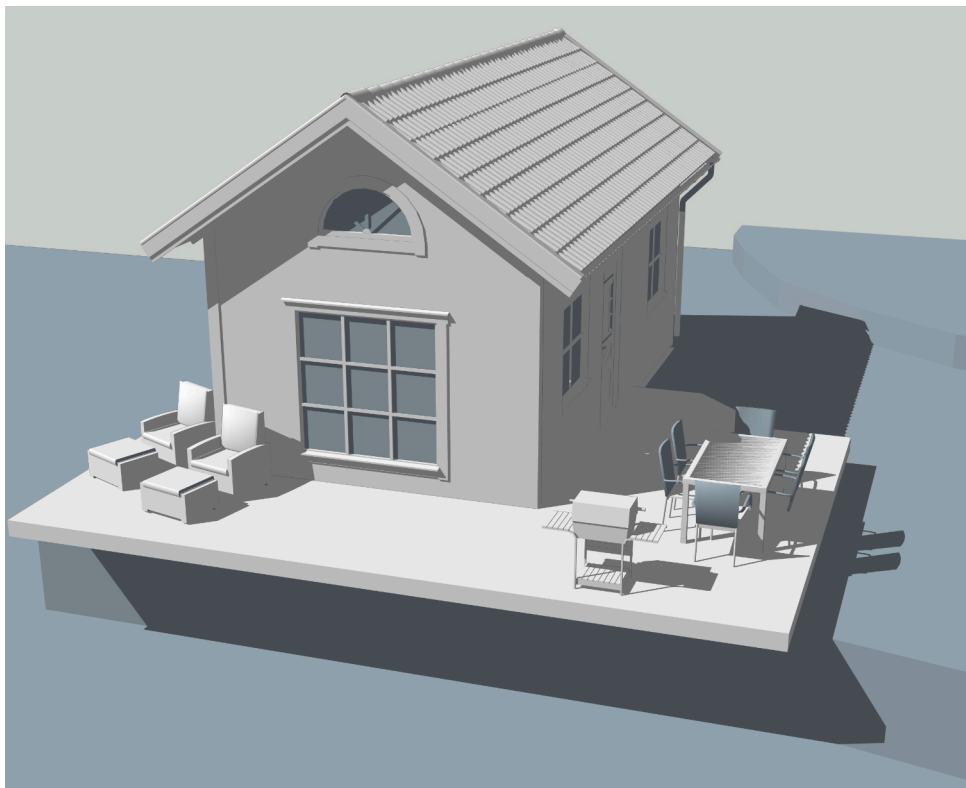

Baksida 18/7 kl 14:00

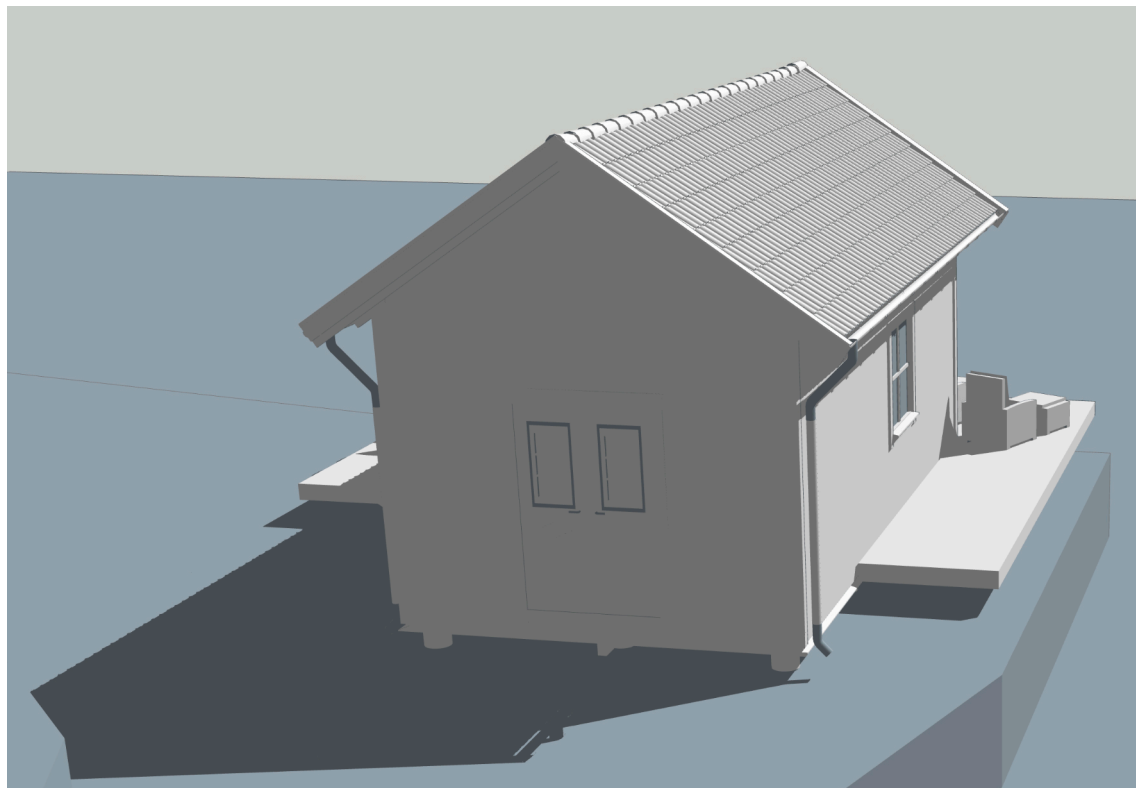

# Fasadritningar

FASAD MOT ÖSTER

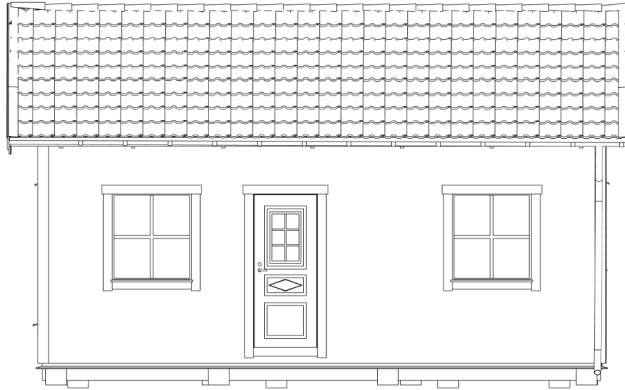

FASAD MOT SÖDER

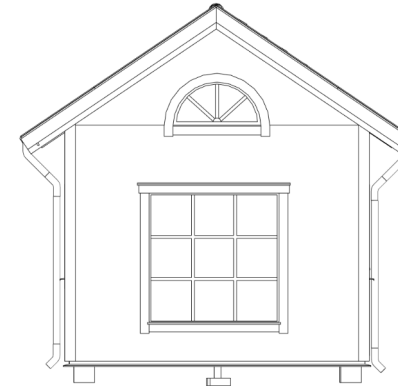

FASAD MOT NORR

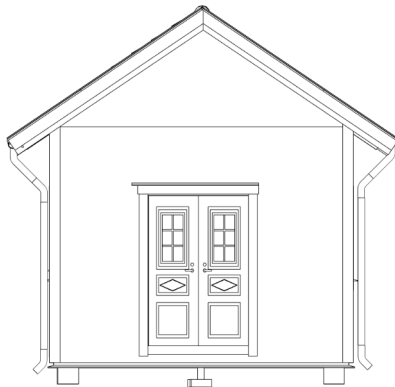

FASAD MOT VÄSTER

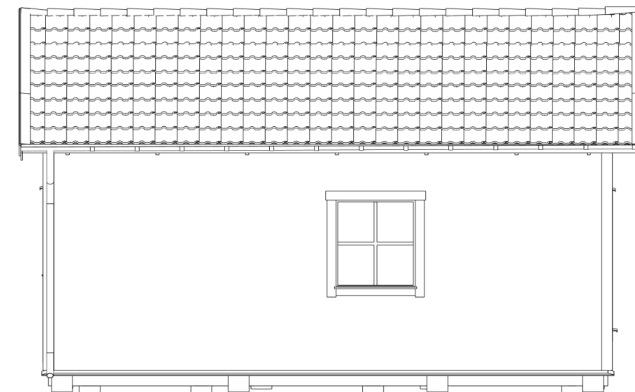

# Plan och Sektionsritning

PLAN 1

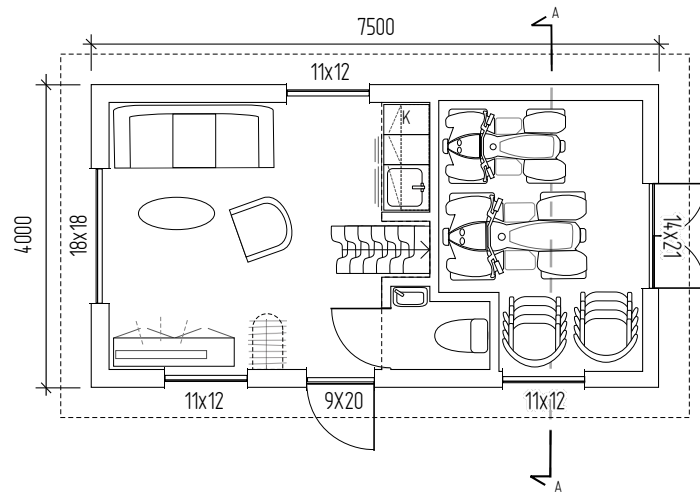

SOVLOFT

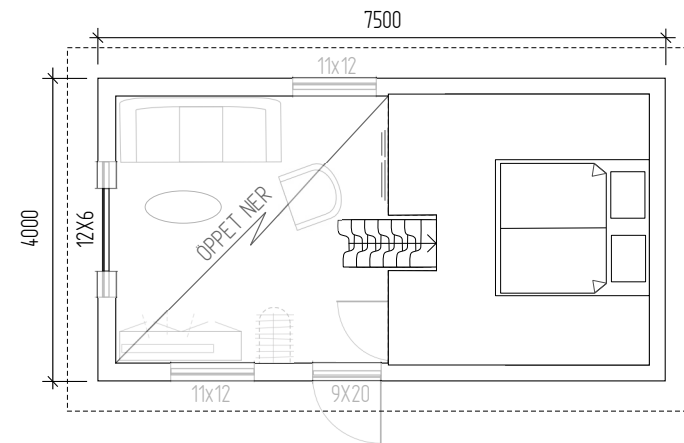

VÄGG/TAK-SNITT

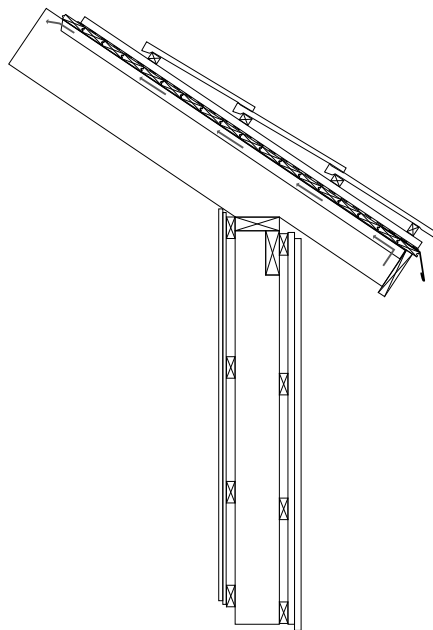

SEKTION A-A

